

NOTES: 1.

TORQUE	PLAIN	BLACK
[INCHES] mm	PART NO.	PART NO.
[3.9] Lb-in 0.44 Nm	29-054	29-154
[6.9] Lb-in 0.78 Nm	29-058	29-158
[10.8] Lb-in 1.22 Nm	29-062	29-162
[13.9] Lb-in 1.57 Nm	29-066	29-166
[17.8] Lb-in 2.01 Nm	29-070	29-170
[20.8] Lb-in 2.35 Nm	29-074	29-174
[24.7] Lb-in 2.79 Nm	29-080	29-180

- TORQUE TOLERANCE: $\pm 20\%$
- LIFE: 50,000 CYCLES WHEN DUTY CYCLE IS LESS THAN 10% AND ROTATIONAL SPEED IS LESS THAN 100 RPM. 30 SECONDS MAXIMUM CONTINUOUS ACTUATION.
- FLATS TO BE ORIENTED $\pm 5^\circ$ WITH RESPECT TO DATUM A AS SHOWN.
- DESIGNED TO ACCEPT M4 OR #8 SCREW OR EQUIVALENT
- USER MUST DETERMINE FITNESS FOR USE IN APPLICATION
- MATERIAL:
 BRACKET IS ZINC
 SHAFT ENDS ARE PLATED STEEL
 - LOW CARBON STEEL WITH ZINC PLATE
 SHAFT AND TORQUE ELEMENT ARE HARDENED STEEL

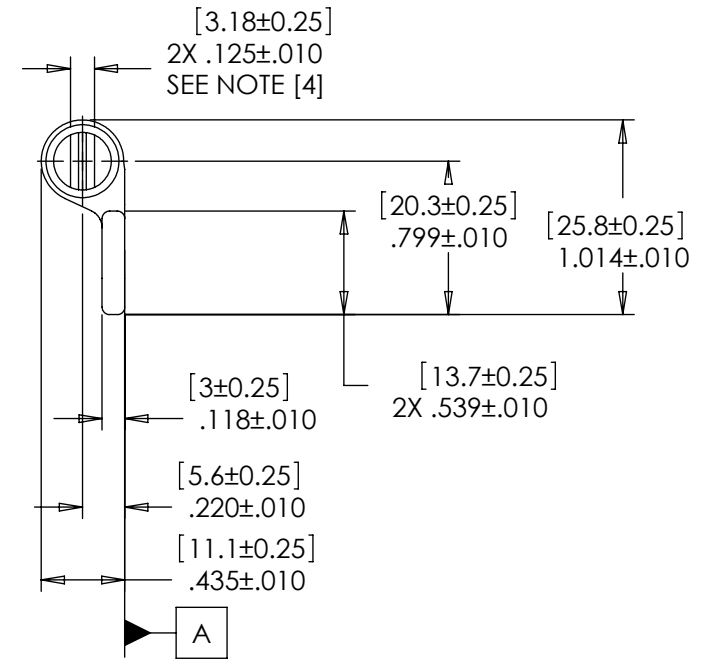
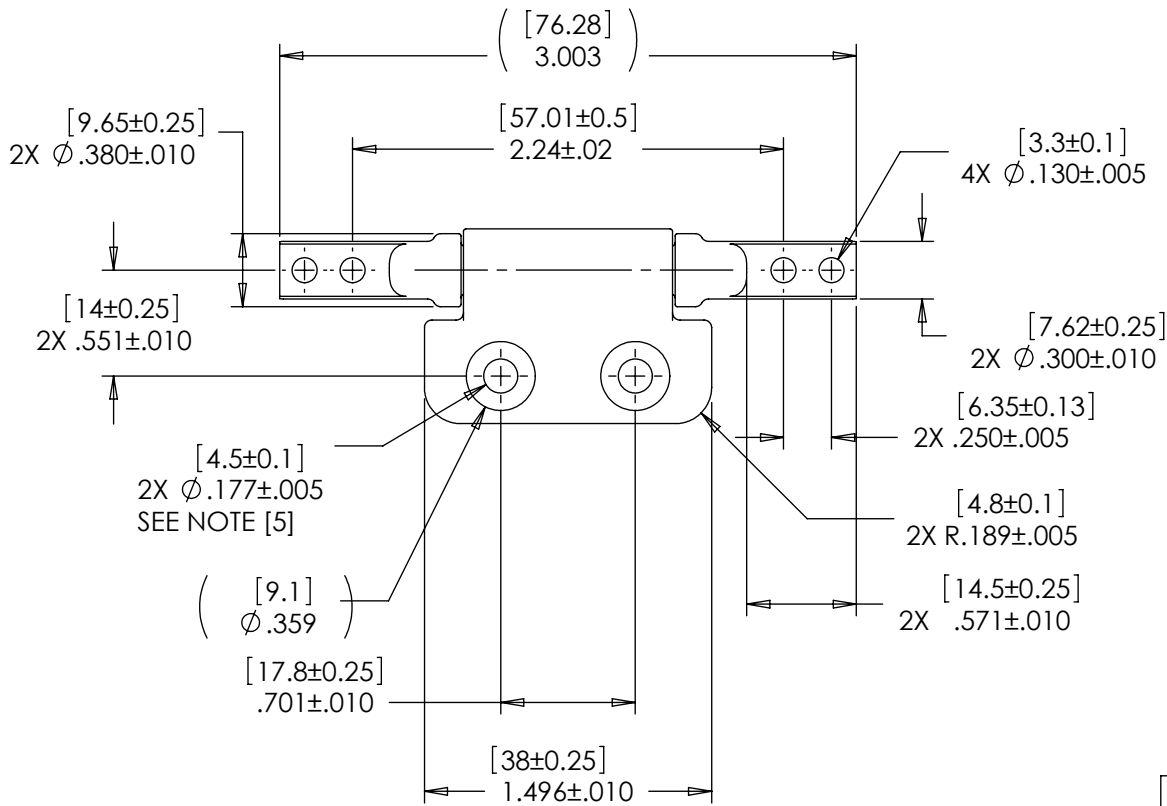

SPECIFICATIONS SUBJECT TO CHANGE

INTERPRET PRINT PER
 ASME Y14.5M-1994
 THIS PRINT IS THE
 CONFIDENTIAL PROPERTY
 OF REELL PRECISION MFG.
 THIRD ANGLE PROJECTION

LEVEL	DESCRIPTION	DRAWN	DATE	APPROVED
DRAWN: HMA	DATE: 3-5-02	PART NO: 29-XXX		
CHECKED: HMA	DATE: 3-5-02	TITLE: POSITIONING HINGE, DUAL		
APPROVED: TWJ	DATE: 3-14-02	DESCRIPTION: PHB SERIES WITH COUNTERSINKS		
REVISED: 12-18-13	DIMS: [mm]IN	SCALE: 1:1 DO NOT SCALE DRAWING		
REELL PRECISION MANUFACTURING 1259 WILLOW LAKE BOULEVARD SAINT PAUL, MINNESOTA 55110-5103, USA				REV: H
SHEET 1 OF 1				