

CATALOG CODE RT-120-XX-XX

TORQUE IN-LBS
20
30
40
50

SHAFT END TYPE
01- FLAG
02- STRAIGHT
03- KNURLED SHAFT END

DYNAMIC TORQUE	
NOMINAL TORQUE (IN-LBS)	TOLERANCE
20	±20%
30	±20%
40	±20%
50	±20%

PRODUCT TORQUE SPECIFICATION AT +20°C.

NOTES:

1. USER MUST DETERMINE FITNESS FOR USE IN APPLICATION.
2. ENVIRONMENTAL CONDITIONS: -20° TO +80°C. UP TO 10% OF LIFE CYCLES AT HOT AND COLD CONDITIONS.
3. LIFE: 50,000 CYCLES.
ONE CYCLE CONSISTS OF 90° CW AND 90° CCW AT 10% DUTY CYCLE FOR SPEEDS LESS THAN 100RPM.
- [4] HINGE DESIGNED TO SUPPORT A MINIMAL AXIAL FORCE IN DIRECTION SHOWN, NOT DESIGNED TO SUPPORT AXIAL FORCE IN THE OPPOSITE DIRECTION.
5. MATERIALS:
ZINC DIE CAST HOUSINGS & FLAG SHAFT ENDS
STEEL STRAIGHT SHAFT ENDS
HARDENED STEEL SHAFT
HARDENED STEEL TORQUE CLIPS
MINERAL OIL BASED LUBRICANT
6. FINISH:
NON-COSMETIC PLAIN.
CLEAR CHROMATE RUST PREVENTATIVE COATING ON THE STRAIGHT SHAFT.
7. SHIP ANGLE 0° ±5° BETWEEN HOUSINGS.
- [8] DESIGNED TO ACCEPT M4 OR #8 SCREW OR EQUIVALENT.

SPECIFICATION SUBJECT TO CHANGE

INTERPRET PRINT PER
ASME Y14.5M-1994
THIS PRINT IS THE
CONFIDENTIAL PROPERTY
OF REELL PRECISION MFG.

THIRD ANGLE PROJECTION

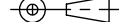

LEVEL	DESCRIPTION	DRAWN	DATE	APPROVED
DRAWN:	TLS	DATE:	23JUN11	REFERENCE:
CHECKED:	BLJ	DATE:	12DEC11	TITLE:
APPROVED:	BLJ	DATE:	12DEC11	
REVISED:	05AUG20	DIMS:	mm	SALES DRAWING
PART NO:			RT-120	REV:
			H	
SCALE: 1:2		DO NOT SCALE DRAWING		SHEET 1 OF 5

REELL PRECISION MANUFACTURING
1259 WILLOW LAKE BOULEVARD
SAINT PAUL, MINNESOTA 55110-5103, USA

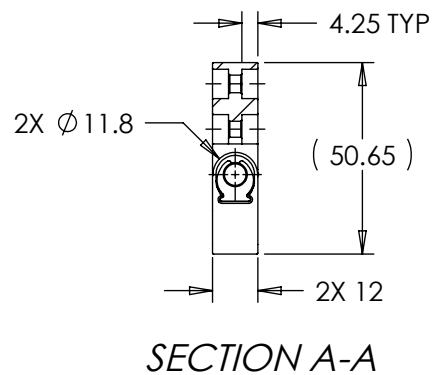
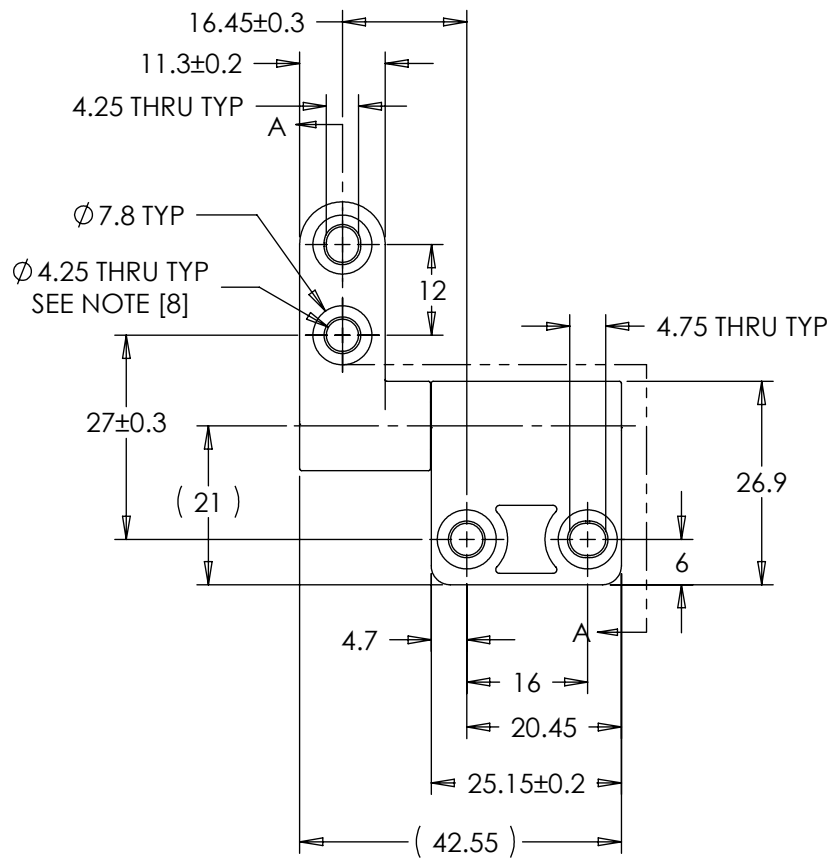

APPROXIMATE WEIGHT: 66 GRAMS

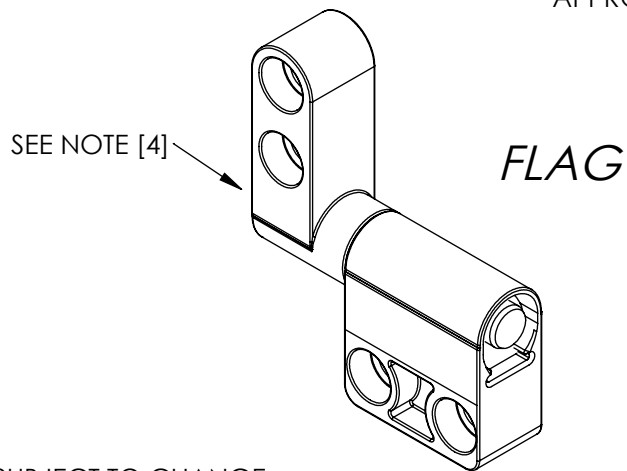

ALL DIMENSIONS REFERENCE
SEE CAD MODEL FOR UNSPECIFIED FEATURES.

LEVEL	DESCRIPTION		DRAWN	DATE	APPROVED
DRAWN:	TLS	DATE: 23JUN11	REFERENCE:		
CHECKED:	BLJ	DATE: 12DEC11	TITLE:		
APPROVED:	BLJ	DATE: 12DEC11	SALES DRAWING		
REVISED:	05AUG20	DIMS: mm			
			PART NO:		REV:
			RT-120		H
REELL PRECISION MANUFACTURING 1259 WILLOW LAKE BOULEVARD SAINT PAUL, MINNESOTA 55110-5103, USA			SCALE: 1:1	DO NOT SCALE DRAWING	SHEET 2 OF 5

INTERPRET PRINT PER
ASME Y14.5M-1994
THIS PRINT IS THE
CONFIDENTIAL PROPERTY
OF REELL PRECISION MFG.
THIRD ANGLE PROJECTION

SPECIFICATION SUBJECT TO CHANGE

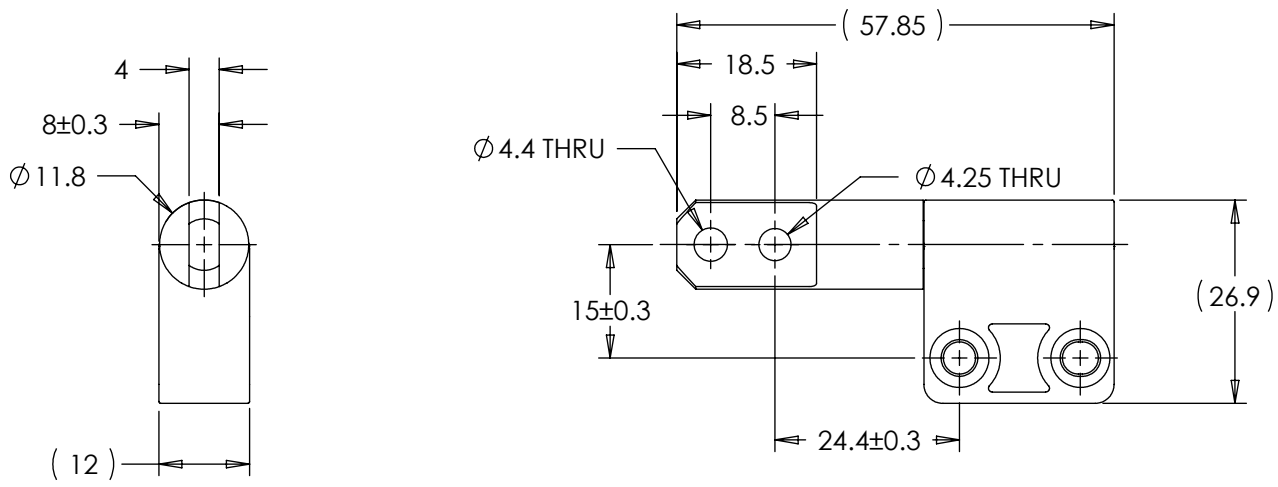

APPROXIMATE WEIGHT: 59 GRAMS

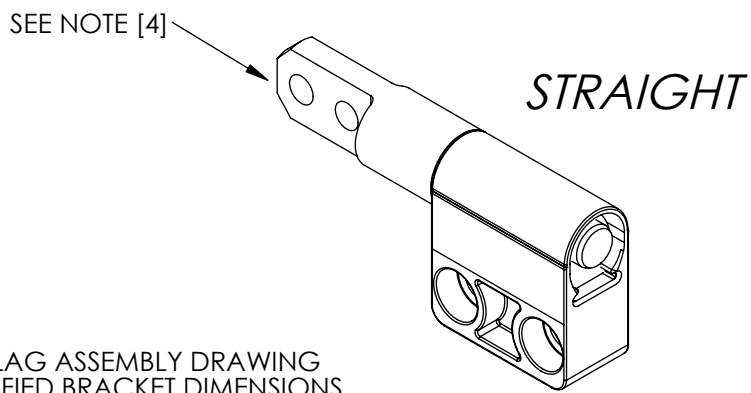

SEE SINGLE FLAG ASSEMBLY DRAWING FOR UNSPECIFIED BRACKET DIMENSIONS

SPECIFICATION SUBJECT TO CHANGE

ALL DIMENSIONS REFERENCE SEE CAD MODEL FOR UNSPECIFIED FEATURES.

LEVEL	DESCRIPTION		DRAWN	DATE	APPROVED
DRAWN:	TLS	DATE: 23JUN11	REFERENCE:		
CHECKED:	BLJ	DATE: 12DEC11	TITLE:		
APPROVED:	BLJ	DATE: 12DEC11	SALES DRAWING		
REVISED:	05AUG20	DIMS: mm			
			PART NO:		REV:
			RT-120		H
REELL PRECISION MANUFACTURING 1259 WILLOW LAKE BOULEVARD SAINT PAUL, MINNESOTA 55110-5103, USA			SCALE: 1:1	DO NOT SCALE DRAWING	SHEET 3 OF 5

INTERPRET PRINT PER ASME Y14.5M-1994
 THIS PRINT IS THE CONFIDENTIAL PROPERTY OF REELL PRECISION MFG.
 THIRD ANGLE PROJECTION

Ø 5.97±0.05
KNURL O.D.

6±0.3

(12)

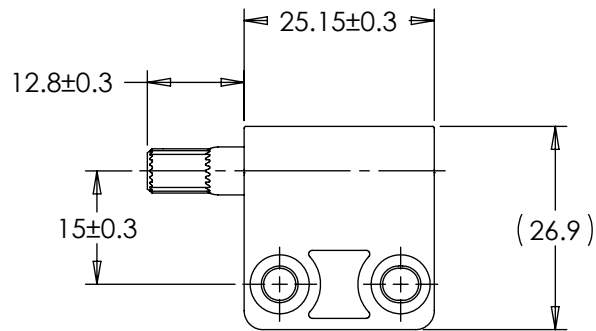

APPROXIMATE WEIGHT: 43 GRAMS

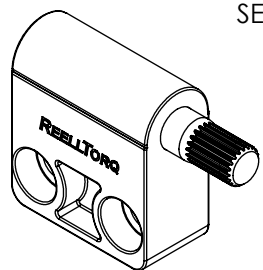

SEE NOTE [4]

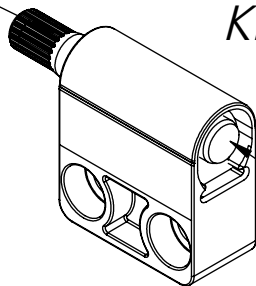

KNURLED SHAFT END

SUPPORT ON
END OF SHAFT
WHEN INSTALLING
PART ONTO KNURL

ALL DIMENSIONS REFERENCE
SEE CAD MODEL FOR UNSPECIFIED FEATURES.

SEE SINGLE FLAG ASSEMBLY DRAWING
FOR UNSPECIFIED BRACKET DIMENSIONS
SPECIFICATION SUBJECT TO CHANGE

INTERPRET PRINT PER
ASME Y14.5M-1994
THIS PRINT IS THE
CONFIDENTIAL PROPERTY
OF REELL PRECISION MFG.
THIRD ANGLE PROJECTION

LEVEL	DESCRIPTION		DRAWN	DATE	APPROVED
DRAWN:	TLS	DATE: 23JUN11	REFERENCE:		
CHECKED:	BLJ	DATE: 12DEC11	TITLE:		
APPROVED:	BLJ	DATE: 12DEC11	SALES DRAWING		
REVISED:	05AUG20	DIMS: mm			
			PART NO:		REV:
REELL PRECISION MANUFACTURING 1259 WILLOW LAKE BOULEVARD SAINT PAUL, MINNESOTA 55110-5103, USA			RT-120		H
THIRD ANGLE PROJECTION			SCALE: 1:1	DO NOT SCALE DRAWING	SHEET 4 OF 5

MATERIAL	D1	D2	L1	L2	OD	WALL	GAP
DIE CAST ZINC	6.23±0.03	5.7±0.03	4.5±0.1	13.25 MIN	10 MIN	1 MIN	0.1 NOMINAL
DIE CAST ALUMINUM							
MILD STEEL	6.4±0.05	5.745±0.015					
WROUGHT ALUMINUM							

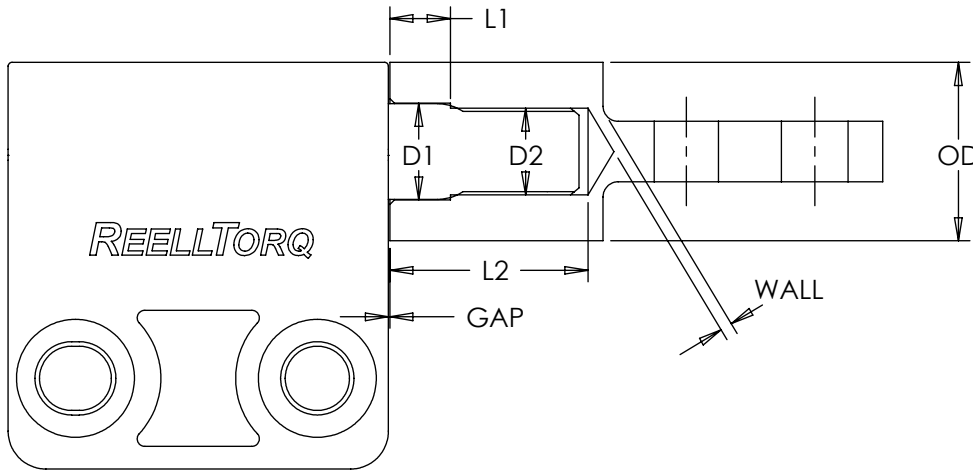

*RECOMMENDED
MATING GEOMETRY
FOR KNURLED
SHAFT END*

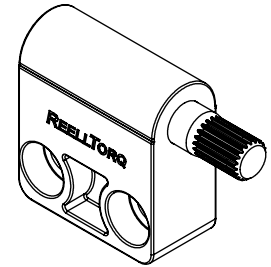

SPECIFICATION SUBJECT TO CHANGE

LEVEL	DESCRIPTION		DRAWN	DATE	APPROVED
DRAWN:	TLS	DATE: 23JUN11	REFERENCE:		
CHECKED:	BLJ	DATE: 12DEC11	TITLE:		
APPROVED:	BLJ	DATE: 12DEC11	SALES DRAWING		
REVISED:	05AUG20	DIMS: mm			
			PART NO: RT-120		REV: H
			SCALE: 1:2		DO NOT SCALE DRAWING

INTERPRET PRINT PER
ASME Y14.5M-1994
THIS PRINT IS THE
CONFIDENTIAL PROPERTY
OF REELL PRECISION MFG.
THIRD ANGLE PROJECTION



REELL PRECISION MANUFACTURING
1259 WILLOW LAKE BOULEVARD
SAINT PAUL, MINNESOTA 55110-5103, USA