



**REELL Precision Manufacturing Corporation**  
1259 Willow Lake Boulevard  
Saint Paul, MN 55110-5103 USA  
Phone: 651.484.2447  
Fax: 651.484.3867  
www.reell.com

**REELL Precision Manufacturing B.V.**  
Business Park Stein 118  
6181 MA Elsloo, Netherlands  
Phone:+31(0)46 42 69169  
Fax:+31(0)46 42 69160  
www.reell.com

---

## PURCHASING SPECIFICATIONS

NUMBER: Supplier Quality Manual (Formerly Spec 292)  
REVISION: H  
RELEASED: 1-8-07  
REVISED: 7-30-20  
APPROVED: Ron Nelson, VP of Operations  
David Titchenal, Director of Global Quality Services  
Jeff Ellingson, Global Purchasing Manager

## SUPPLIER QUALITY MANUAL

### 1. Responsibility for Quality

The supplier will be responsible for the quality of parts supplied to any Reell Precision Manufacturing location including contract manufacturers acting as an agent for Reell Precision Manufacturing. Reell does not routinely perform incoming inspection on component parts; therefore, the supplier must have adequate systems in place to assure quality. Contact Reell if you have any questions regarding these requirements or need assistance in developing an effective quality plan. Supplier qualification is a decision made jointly by functional representation from purchasing, quality and engineering.

### 2. Purchase Order Terms and Conditions

Refer to Reell Spec 291 for Supplier Purchase Order Terms and Conditions. The latest revision is called out on the Supplier Purchase Order. Contact Global Purchasing to obtain a copy of this specification, (as needed).

### 3. REACH, RoHS, Prop 65 & Conflict Minerals (Formerly Spec 280)

Reell expects its suppliers (including packaging or contract manufacturers) to conform with the following statutory / regulatory requirements: (Note: Reell suppliers are responsible for complying with the latest requirements.)

**EU RoHS:** <http://RoHSguide.com>

REELL requires that all parts and materials supplied to us shall comply with the substance restrictions of the RoHS Directive.

**EU REACH:** <http://echa.europa.eu/web/guest/candidate-list-table>

The European REACH Regulation ((EC) No 1907/2006) regulates a large number of substances, better known as SVHC's or "Substance of Very High Concern". Note that more substances are added to the substance Candidate list approximately every 6 months.

**California Prop 65:** <http://oehha.ca.gov/proposition-65>

**China RoHS:** <http://www.thecompliancemap.com/news/china-rohs-2-regulation-finalized.php>

**JISC 0950:2008 and J-Moss:** [http://home.jeita.or.jp/eps/jmoss\\_en.htm](http://home.jeita.or.jp/eps/jmoss_en.htm)

**Japan CSCL:** [http://www.chemsafetypro.com/topics/japan/japan\\_cscl\\_chemical\\_substance\\_control\\_law.html](http://www.chemsafetypro.com/topics/japan/japan_cscl_chemical_substance_control_law.html)

**US Conflict Minerals:** <https://info.assentcompliance.com>

REELL requests an updated Smelters List when returning this form.

**Supplier Declarations:** Upon this request by REELL, the supplier declares that all parts and materials supplied to REELL are in compliance with the Key Regulations listed above.

#### 4. Revision Level

Upon order for tooling and/or parts, Reell will issue a released print specifying revision level. All quality records submitted to Reell must include the revision level of the parts that the record represents.

#### 5. Product Quality

All items with the “<ST>” symbol on dimensions, specifications or notes require the use of Statistical Process Control (SPC) charts. The required minimum Cpk for these dimensions is 1.33 (+/- 4 Sx) unless otherwise stated on the drawing.

#### 6. Measurement Reports

Inspection data and material certifications for each lot shall be retained by supplier and reviewed by authorized supplier personnel to assure the quality of parts produced. This inspection data must be filed and be available upon request for audit purposes. Where required by REELL, CoC documents must accompany product shipment and reflect each production lot contained in the shipment. Inspection data, deviation issued by Reell, and material certification shall be maintained a minimum of 5 years (10 years preferred).

#### 7. Part Submission Warrant (PSW)/Production Part Approval Process (PPAP) Requirements

On all new parts or products, tool changes, or significant drawing changes, Reell typically requires a level 3 PPAP (Production Part Approval Process). Specific requirements will be communicated via a PSW form or an industry standard PPAP such as CQI, Special Process Assessment Document. When required as part of the PPAP, this will be flowed down to the supplier as part of the 1<sup>st</sup> Article Approval. Note: Once Qualified, the supplier is required to update this document and submit yearly via [Quality@Reell.com](mailto:Quality@Reell.com)

##### **The PSW may include the following or additional requirements:**

- **First Article Inspection** (per cavity if applicable) – Reell requires the supplier to submit data and components for a 3- piece first article inspection for all items on the drawing (dimensions and notes). This is required for tooling samples (if applicable) or first shipment from production “hard” tooling (parts measured will be serialized and submitted).
- **Process Control Plan** – The control plan may also be referred to as a Quality Plan. Quality/Control plans should include incoming (IQC), in-process (IPQC) and outgoing (OQC) quality control requirements and any special process characteristics required by Reell. Ref. section 3 for requirements on controls.
- **Capability Study** – Capability studies are to be conducted on those items indicated on the Part Submission Warrant (PSW). Those studies normally include all items specified on the drawing with the <ST> symbol and may include other critical dimensions for which variable data can be obtained. The Capability Study must include documentation of average (mean), standard deviation, Cp and Cpk. Sample size quantity is 32 pieces unless otherwise specified on the PSW. Cpk minimums are either defined on the drawing or in the supplier’s Quality Control Plan. Suppliers are encouraged to perform process studies, even when not required in the PSW.

When submitted PSWs or PPAPs are approved, tooling will be approved, and tooling payment can be issued. All items not meeting the print must be corrected by the supplier at the supplier’s expense unless Reell issues a written deviation accepting the tool in its present condition or pending a print revision.

#### 8. Quality Control: Nonconforming Materials, and Supplier Correct Action Reports (SCARs)

If a supplier's parts are found to be nonconforming, the supplier will be notified by Reell Precision Manufacturing personnel using a Supplier Corrective Action Report (SCAR) form.

A Reell SCAR form is sent when a nonconformance occurs that requires a supplier disposition (parts return or credit), significant rework, or expense. An initial response and containment plan is required within 48 hour of receiving a SCAR form. The completed SCAR form (or a supplier’s internal form such as an 8D, 5D, etc.) must be returned to Reell within 21 days of receiving the SCAR form. Implementation of identified long term corrections may exceed 21 days, but the completed

form with root cause, short- and long-term corrections with implementation date and responsible person must be returned within 21 days.

Parts requiring a supplier disposition shall be addressed per the Terms and Conditions.

Reell Precision Manufacturing reserves the right to recover from the supplier all costs reasonably incurred with mutual consent in the course of addressing a supplier caused nonconformance including, but not limited to, rework, labor, customer charges, travel, etc.

## **9. Quality Control: Deviations and Required Reviews prior to shipment**

Items that do not meet drawing specifications or satisfy Cpk targets require a written deviation from Reell prior to shipment. The deviation must accompany the shipments.

In addition, the following changes require review and written approve from Reell prior to shipment.

- Changes in manufacturing location
- Process changes that may affect fit, form or function
- New tools
- Changes in sub-contract/sub-tier suppliers  
Note: sub-contract/sub-tier suppliers already approved for one part are not automatically approved for use on another part.
- No changes shall be allowed in material(s), regardless of whether material is considered equivalent, without prior written approval by Reell.

## **10. Agreement Verification**

Reell or Reell's Contract Manufacturer's reserve the right to audit each supplier and any supplier's sub-contract/sub-tier suppliers at reasonable times as needed.

## **11. Customer Owned Tooling**

Supplier must identify, control, maintain and store customer supplied tooling as communicated by Reell Supplier Quality usually during the FAI phase. This may be followed up during subsequent on-site visits or audits.

## **12. Additional controls for Contract Manufacturer's**

For Incoming Quality Control (IQC), the Contract Manufacturer (CM) is required to verify through documented IQC inspection records that sub-tier Suppliers are providing product that meets Reell requirements. Reell reserves the right to audit these IQC inspection records.

## **13. Product Identification and Traceability**

The following information shall be identified on all shipping cartons and shipping documentation and in this order in the QR Code:

Reell part number  
Reell revision letter  
Quantity  
Reell lot number  
Reell purchase order number  
Supplier Name  
Country of Origin  
Ship Date  
Box \_\_ of \_\_

The Reell Lot number consists of the last three digits of the Suppliers Reell Supplier ID code, the two-digit year code and the three-digit Julian date code. This is based upon the date of manufacture and not the ship date (Figure 1).

Figure 1

REELL Supplier ID Code	2 Digit Year Code	3 Digit Julian Date Code
50000263	19	032
263	19	032

#### 14. Component Package Marking

1. The following information must be placed on a minimum of two adjacent sides of all cartons via labels printed per Figure 2 Component Package Marking **including QR Code**. Where possible, labels or symbols shall be 3 inches minimum from the corners of the package. Label size, the label width shall be 6 inches. The label height shall be 4 inches depending on the needs and abilities of the supplier. *(Contact Global Purchasing for deviations from the label size specification.)*

**REELL Labels (Version A thru C):**

1.) **REELL Label Version A:** Version A is used for identifying individual cartons which are located on pallets. Each carton must contain two REELL Production Labels on adjacent sides.

**Note:** The Reell address listed is just an example – address may be to a different location.

**PRODUCTION LABELS**

Figure 2

<b>20 Point Font Size</b>	<b>From:</b>		<b>To:</b>
	Supplier Name		Reell Precision Manufacturing
<b>14 Point Font Size</b>	Street Address		1259 Willow Lake Boulevard
	City, State, Zip		Saint Paul, MN 55110-5103 USA
	<b>Part# - 123456-000</b>		
	<b>Revision - C</b>		
<b>Quantity - 5000</b>			
<b>Lot # - 26319032</b>			
	<b>REELL P.O. # - 789123</b>	<b>Ship Date - 2/26/2019</b>	
	<b>Supplier - Testco</b>	<b>Box ____ of ____</b>	
	<b>Country of Origin - USA</b>		

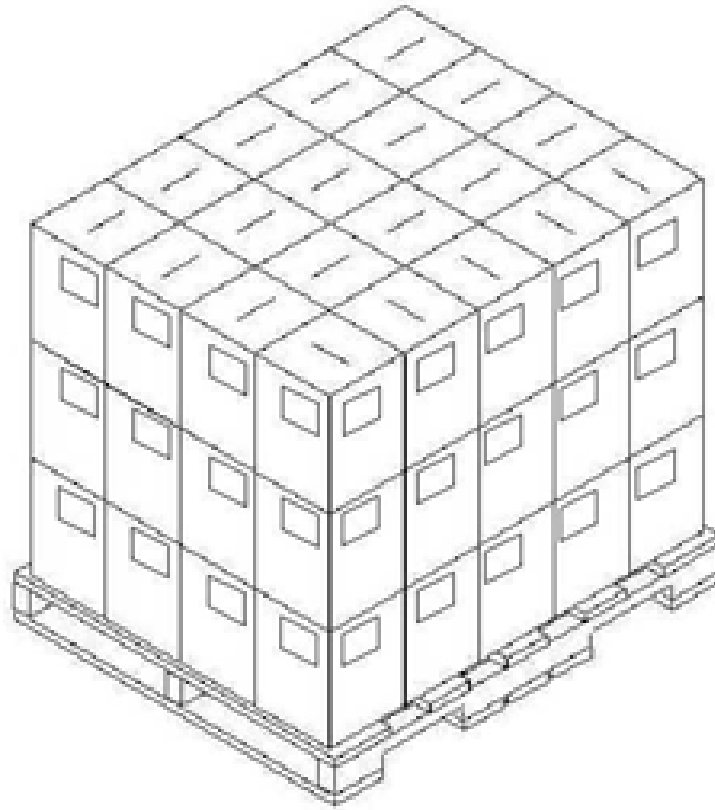

2.) **REELL Label Version B:** Version B is used to identify a pallet load of the same part numbers. Each pallet load must contain two REELL Labels on adjacent sides and each carton must contain two REELL Production Labels on adjacent sides.

**Note:** The Reell address listed is just an example – address may be to a different location.

#### MASTER LOAD LABEL

<b>From:</b> Supplier Name Street Address City, State, Zip	<b>To:</b> Reell Precision Manufacturing 1259 Willow Lake Boulevard Saint Paul, MN 55110-5103 USA
<b>Part# - 123456-000</b> <b>Revision - C</b> <b>Quantity - 100000</b> <b>MASTER LOAD</b>	
<b>REELL P.O. # - 789123</b> <b>Supplier - Testco</b> <b>Country of Origin - USA</b>	<b>Ship Date - 2/26/2019</b> <b>Box ____ of ____</b>

**20 Point Font Size**

**24 Point Font Size**

**14 Point Font Size**

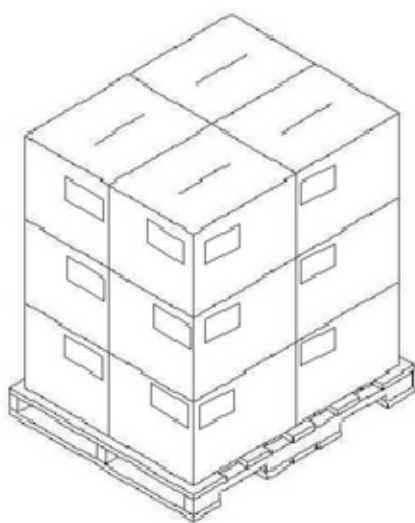

**Labels (two per carton)**

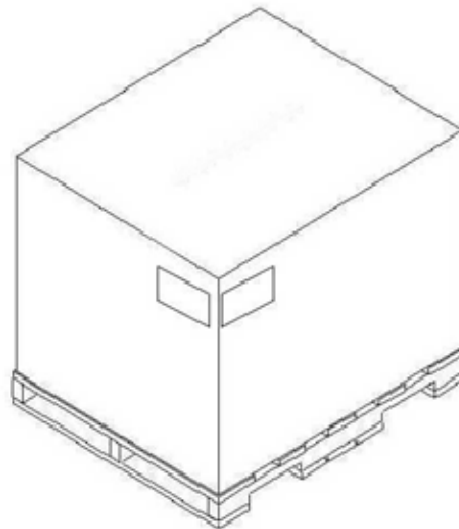

**(2) Labels on stretch wrap**

**3.) REELL Label Version C: Version C is used to identify a pallet load of different part numbers. Each pallet load must contain two REELL Labels on adjacent sides and each carton must contain two REELL Production Labels on adjacent sides.**

**Note: The Reell address listed is just an example – address may be to a different location.**

**MIXED LOAD LABEL**

**36 Point  
Font Size**

**14 Point Font Size**

<b>From:</b> Supplier Name Street Address City, State, Zip	<b>To:</b> Reell Precision Manufacturing 1259 Willow Lake Boulevard Saint Paul, MN 55110-5103 USA	
<b>MIXED LOAD</b>		
		
REELL P.O. # -	789123	Ship Date - 2/26/2019
Supplier -	Testco	
Country of Origin -	USA	Box ____ of ____

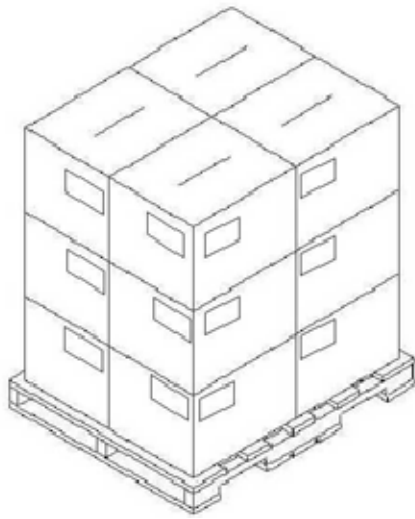

**Labels (two per carton)**

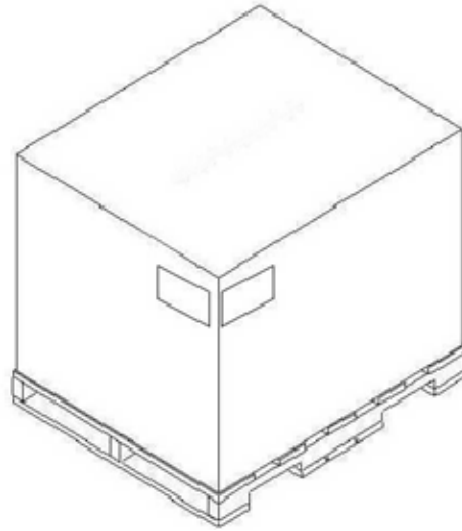

**(2) Labels on stretch wrap**



## Appendix

### Table 1 Part Submission Warrant Requirements

Requirements	Level 1	Level 2	Level 3	Level 4
1 Design Records (Prints/Specs)			*	*
2 Process Flow Diagrams			S	*
3 Process FMEA			S	*
4 Dimensional Results, FAI		S	S	*
5 Capability Study's			S	*
6 Measurement System Analysis Studies (GR&R)			S	*
7 Control Plan			S	*
8 Material Certification			S	*
9 Part Submission Warrant (PSW)	S	S	S	*
10 Sample Product		S	S	*
11 Inspection Gauge Calibration Records			*	*

S = The supplier shall submit this document to the person(s) listed on the Warrant Form and retain a copy of records for future reference.

R = The supplier shall retain at appropriate locations, including manufacturing, and make readily available to the customer representative upon request.

\* The supplier shall submit to Reell upon special request.