

TI-300 Installation Guide

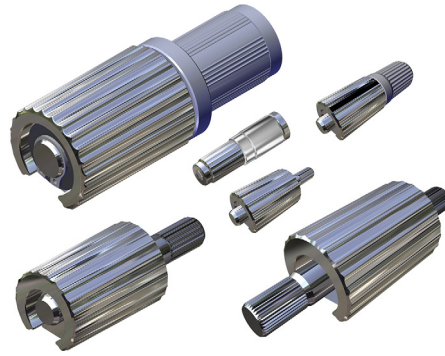

TI-300 Series Torque Inserts enable reliable and precise positioning of equipment and components for a wide range of hinging applications in a variety of markets. Installation requires a few simple steps defined in this document to create a hidden, torque enabled pivot point.

TI-300 Series Torque Inserts are Available in Multiple Configurations



TI-320
.50 - 150 N-m

TI-330
1.0 - 250 N-m

TI-340
2.00 - 650 N-m

TI-360
6.0 - 100 N-m

Installation Tools Required

1. A tool to accurately apply force to the housing body along the torque insert and installation hole center axis, such as an arbor press or mechanical ram.
 - a. Care should be taken to ensure consistent force is applied and the material is properly supported as shown in these instructions.
 - b. Installation force varies by material and hole size. General guidelines for forces required:
 - i. TI320 – 1 ton press
 - ii. TI330 – 2 ton press
 - iii. TI340 – 2 ton press
 - iv. TI360 – 3 ton press
2. A base or clamp to secure and align pieces to press together.
3. A shim or tool stop, depending on the overall assembly, to ensure proper spacing between rotating halves of customer assembly and to ensure the force is applied to the housing and not the shaft.

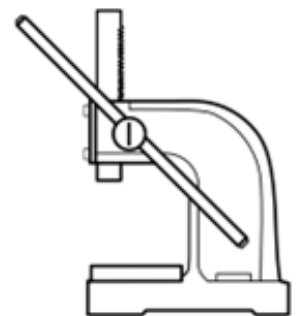

Example: Arbor Press

Important Installation Considerations

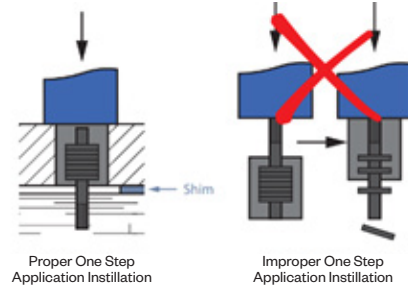
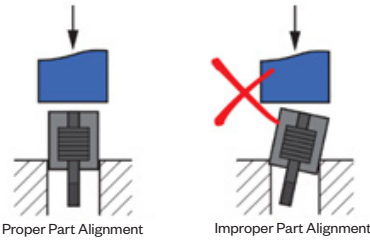

Part alignment is critical. Design base and press ram to align torque insert with port and apply force evenly to the housing.

Do not pound torque insert into place. Impact forces may cause damage to torque insert.

Do not apply force to shaft independent of the body. Shaft can be pressed out of the main body if not supported.

Installation Steps

Step 1: Create Installation Hole

Refer to correct product Sales Drawing at Reell.com for specific dimensional requirements. Proper hole dimensions are critical. If too large, the torque insert may not grip securely. If undersized, the installation may be difficult. 2° draft or less recommended. If draft is present measure the diameter at the midpoint, aligned with the location of the torque insert.

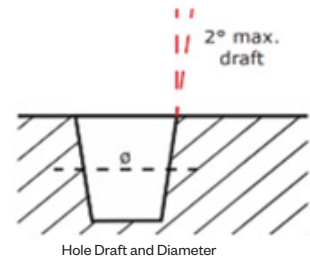

Step 2: Press In Torque Insert

Depending on the overall final product design, installation may require 1, 2, or multiple steps. Refer below for guidelines for each scenario:

One-Step Installation

One-step installation is quick and easy by press fitting the torque insert into a round hole without the use of any mounting hardware. An arbor or pneumatic press ram contacts the entire area of the large housing end of the torque insert. With both the housing and shaft pressed simultaneously, the torque insert is pressed into both materials in one stroke.

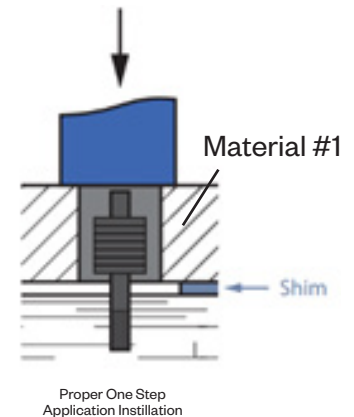

To hide the torque insert completely, recess into material #1 and add a cap to conceal.



REELL PRECISION MFG
Innovative Torque Solutions

Reell.com
info@Reell.com

Two-Step Installation

When utilizing a two-step installation, the torque insert is completely concealed by the rotating parts.

If your application requires the torque insert housing to be installed into a material first, the press ram must contact housing while avoiding contact with the shaft. Do not press on shaft alone as this may shift the clips and shaft out of the housing.

NOTE: If a gap is needed between materials, use a shim or external ram stop.

Step 1
Press the housing into the first material

Step 2
Press the second material onto the shaft using a shim to ensure spacing if necessary

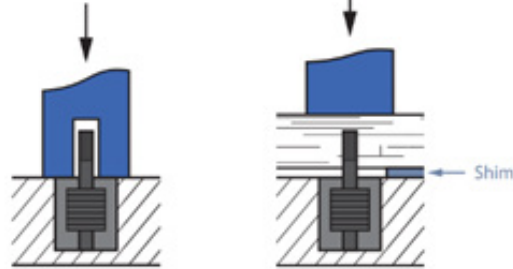

More Than Two Step Installation

Dual Ended models may require more than two insertions/presses. See the following three-step example installation for a Dual Ended Knurled Shaft torque insert.

Step 1
Press the housing into the first material

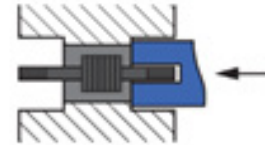

Step 2
While supporting the opposite side of the shaft, press the second material onto one end of the shaft

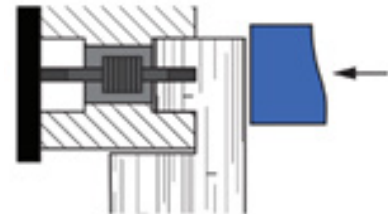

Step 3
While supporting the second material, press the third material onto the other end of the shaft

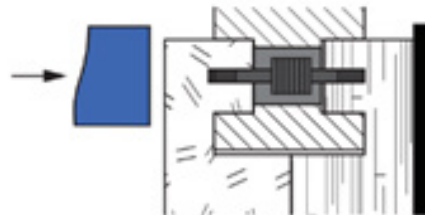

Key Product Design Considerations

Axial Retention

TI300 Series Torque Inserts are not designed to support axial force along the axis of rotation. Excessive forces may cause the shaft to shift and negatively impact product design. Axial forces must be supported by the overall design, and not the TI300 torque insert, to ensure the insert can not be pulled apart. This applies to both vertical and horizontal orientations.

Proper Axial Force Direction

Materials will contact each other if load is applied as shown in figure 1.

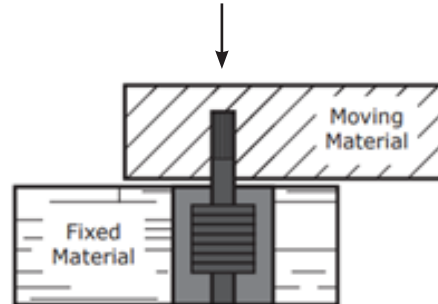

Figure 1: Proper Axial Force Direction

Improper Axial Force Direction

Materials will separate when load is applied as shown in figure 2.

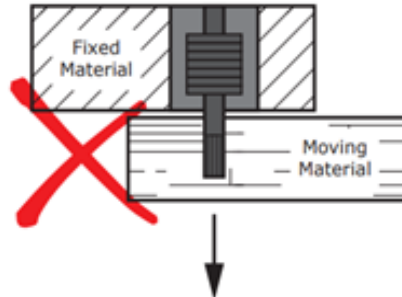
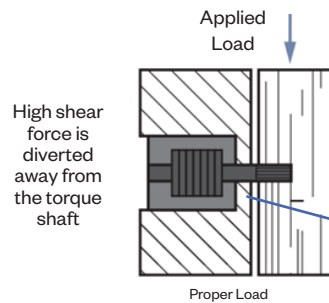

Figure 2: Improper Axial Force Direction

High Radial Load (Shear Force or Abuse Loads)

TI-300 Torque Inserts are designed to provide torque only. The Customer's overall design should account for and support both axial and radial loads.



Proper Load

Note: Shaft is supported. Additional support may be required for higher loads.

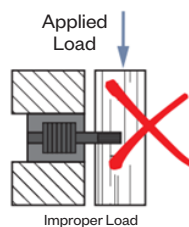

Improper Load

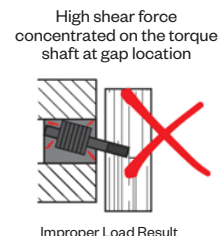

Improper Load Result

Additional Notes and Guidelines

1. **Customer Testing** - Product recommendations and installation instructions provided as general guidance. Many factors may impact final product performance. Reell strongly advises customers to test our product in their end use application to confirm acceptable performance.

2. **Material Compatibility** - TI300 series torque inserts contain mineral oil-based lubricants. Inserts are maintenance free and do not require additional lubrication over life of use. Check compatibility of oil-based lubricants when inserting them into materials such as plastics.

3. **Sealed Design** - To improve weatherability in outdoor applications an o-ring seal can be considered in the design to seal the torque insert from the elements. Product cycle life may be impacted if product is exposed to environmental elements such as moisture, salt, cleaners or solvents. Contact Reell if your application is intended for extreme temperatures.

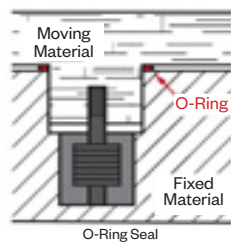

4. **Painting and Plating** - TI300 torque inserts can be installed before or after plating or painting done to the final product. Consider the following:

- a. If installing after plating or painting has been applied to the installation site, do not include the coating thickness when taking measurements.
- b. Do not submerge torque inserts in painting or plating bath.
- c. Minimize any torque insert exposure to chemicals, particularly chemicals that may eliminate the internal lubricants.
- d. If powder coating after installation, do not expose torque insert to temperatures exceeding 80°C.

5. **Wall Thickness** – side and end wall thickness should be considered based on the materials of design and the application. Reference the correct TI300 Sales Drawing for general wall thickness guidelines in and around this press fit. Wall section strength may be impacted by a variety of things such as manufacturing methods, thickness, and environmental exposure. Customers must evaluate these and other factors and test to ensure the overall product design will perform acceptably for the intended end product life and wall thickness is adequate for the loads in the application.



REELL PRECISION MFG
Innovative Torque Solutions

Reell.com
info@Reell.com