

CATALOG CODE	DYNAMIC TORQUE			
	FORWARD		REVERSE	
	Nm	LB-IN	Nm	LB-IN
vTILT-100-3.0-D-XX	3 ± 0.75	26.6 ± 6.7	1.88 ± 0.66	16.6 ± 5.9
vTILT-100-4.0-D-XX	4 ± 0.8	35.4 ± 7.1	2.50 ± 0.75	22.1 ± 6.7
vTILT-100-5.0-D-XX	5 ± 1.0	44.3 ± 8.9	3.13 ± 0.94	27.7 ± 8.4
vTILT-100-6.0-D-XX	6 ± 1.2	53.1 ± 10.7	3.75 ± 1.13	33.2 ± 10.1
vTILT-100-8.0-D-XX	8 ± 1.6	70.8 ± 14.2	5.00 ± 1.50	44.3 ± 13.4
vTILT-100-8.8-D-XX	8.8 ± 1.76	77.9 ± 15.6	5.50 ± 1.65	48.7 ± 14.7
vTILT-100-5.0-OW-BK	5 ± 1.0	44.3 ± 8.9	0.9 MAX	8.0 MAX
vTILT-100-6.0-OW-BK	6 ± 1.2	53.1 ± 10.7	0.9 MAX	8.0 MAX
vTILT-100-7.0-OW-BK	7 ± 1.4	62.0 ± 12.5	0.9 MAX	8.0 MAX
vTILT-100-8.0-OW-BK	8 ± 1.6	70.8 ± 14.2	0.9 MAX	8.0 MAX
vTILT-100-8.8-OW-BK	8.8 ± 1.76	77.9 ± 15.6	0.9 MAX	8.0 MAX

NOTES:

1. STATIC TORQUE IS NORMALLY WITHIN 10% OF DYNAMIC TORQUE
2. LIFE: 20,000 CYCLES MIN. ONE CYCLE CONSISTS OF 90° OPEN AND 90° CLOSED, 5 CYCLES PER MINUTE MAX.
3. COUNTERBORE HOLE PATTERN DESIGNED TO MEET VESA MIS-D, 75/100, C.
4. MATERIAL:
SLEEVE AND BUSHING: ZINC DIE CAST
SHAFT AND TORQUE ELEMENT: HARDENED STEEL
PLATE AND SWIVEL BODY: ENGINEERED PLASTIC
MINERAL OIL BASED LUBRICANT
5. MAXIMUM MONITOR WEIGHT 11.3 Kg (25 LBS).
6. USER MUST DETERMINE FITNESS FOR USE IN APPLICATION.

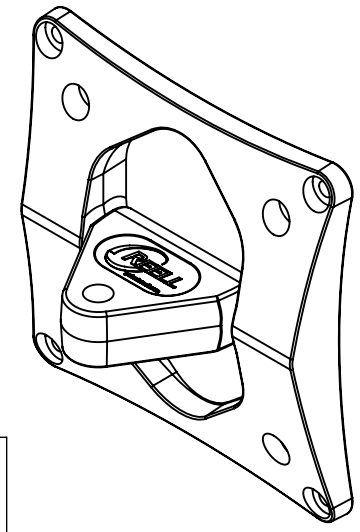

CATALOG CODE

vTILT-100-X.X-XX-XX

STANDARD VESA MOUNTING PATTERN

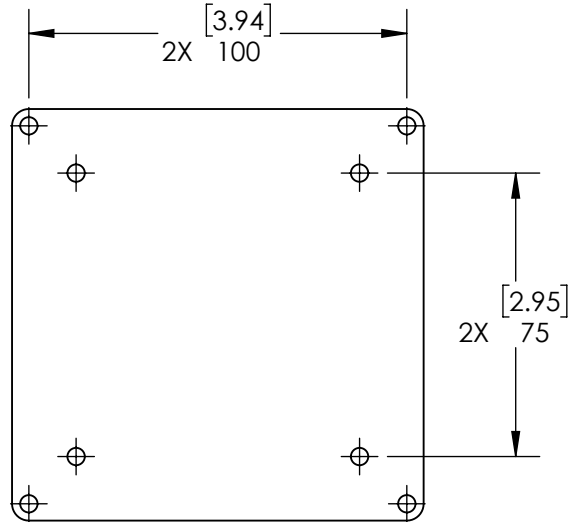

TORQUE Nm
3.0
4.0
5.0
6.0
7.0
8.0
8.8

TYPE
D - DIFFERENTIAL
OW - ONE WAY

COLOR
BK - BLACK
WH - WHITE

	ECO NO: 07919	PART LIFECYCLE: RELEASED
	APPROVED BY: BOB WAHLSTEDT	DEVELOPMENT CYCLE: PRODUCTION
	APPROVED DATE: 14FEB25	DESCRIPTION:
	PROJECT NO: 100341	SALES DRAWING
ENGINEER: BOB WAHLSTEDT		
REELL PRECISION MANUFACTURING 1259 WILLOW LAKE BOULEVARD SAINT PAUL, MINNESOTA 55110-5103, USA	DRAWN BY: BOB WAHLSTEDT	PART NO: vTILT-100
THIS PRINT IS THE CONFIDENTIAL PROPERTY OF REELL PRECISION MFG.	THIRD ANGLE PROJECTION 	REV: N
INTERPRET PRINT PER ASME Y14.5M-2009	DIMENSIONS: mm [IN]	SCALE: 1:2 DO NOT SCALE DRAWING SHEET 1 OF 2

SPECIFICATIONS SUBJECT TO CHANGE.

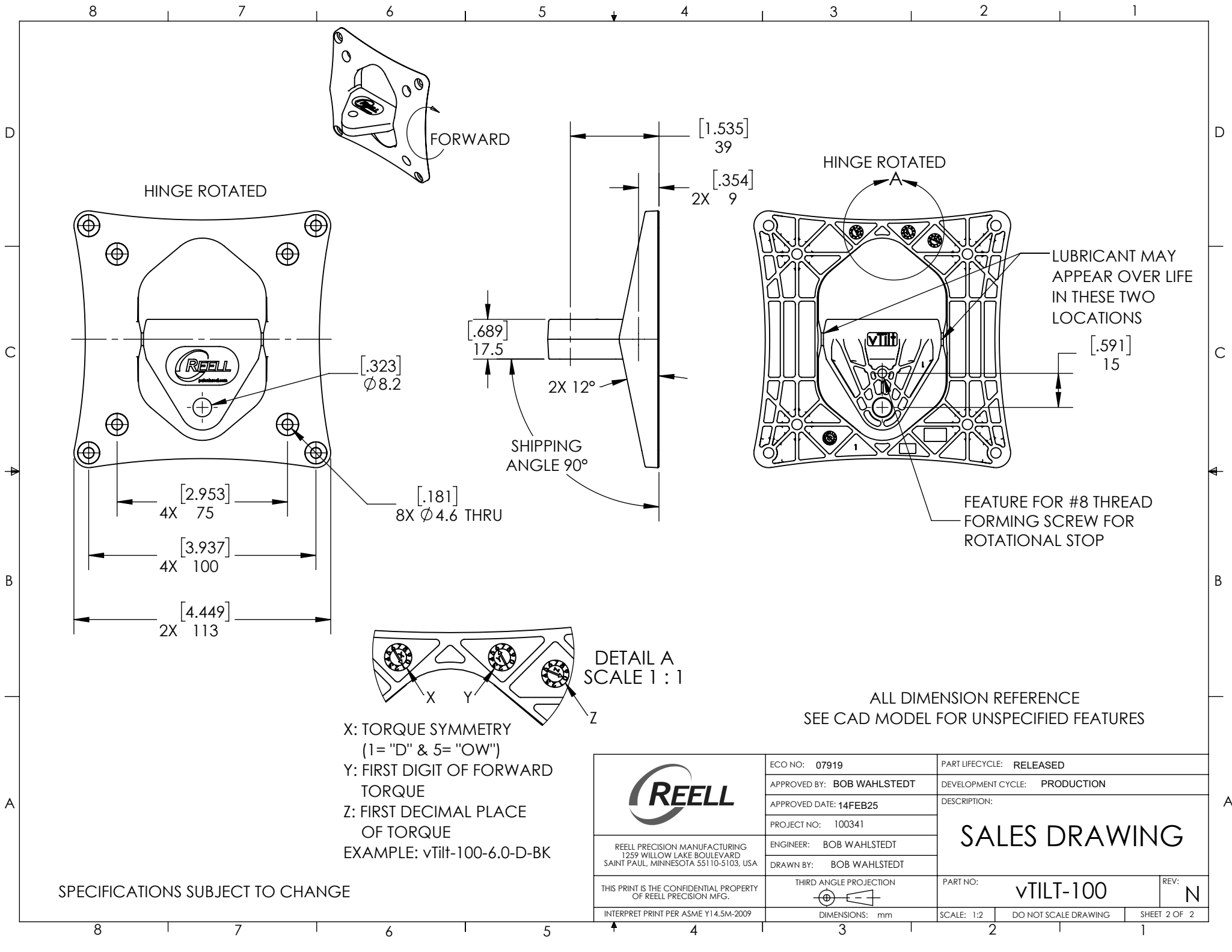

HINGE ROTATED

FORWARD

HINGE ROTATED

LUBRICANT MAY APPEAR OVER LIFE IN THESE TWO LOCATIONS

FEATURE FOR #8 THREAD FORMING SCREW FOR ROTATIONAL STOP

SHIPPING ANGLE 90°

DETAIL A SCALE 1:1

ALL DIMENSION REFERENCE SEE CAD MODEL FOR UNSPECIFIED FEATURES

X: TORQUE SYMMETRY (1= "D" & 5= "OW")
 Y: FIRST DIGIT OF FORWARD TORQUE
 Z: FIRST DECIMAL PLACE OF TORQUE
 EXAMPLE: vTilt-100-6.0-D-BK

SPECIFICATIONS SUBJECT TO CHANGE

	ECO NO: 07919	PART LIFECYCLE: RELEASED
	APPROVED BY: BOB WAHLSTEDT	DEVELOPMENT CYCLE: PRODUCTION
	APPROVED DATE: 14FEB25	DESCRIPTION:
	PROJECT NO: 100341	SALES DRAWING
ENGINEER: BOB WAHLSTEDT	PART NO: vTILT-100	
REELL PRECISION MANUFACTURING 1259 WILLOW LAKE BOULEVARD SAINT PAUL, MINNESOTA 55110-5103, USA	DRAWN BY: BOB WAHLSTEDT	REV: N
THIS PRINT IS THE CONFIDENTIAL PROPERTY OF REELL PRECISION MFG.	THIRD ANGLE PROJECTION 	SCALE: 1:2
INTERPRET PRINT PER ASME Y14.5M-2009	DIMENSIONS: mm	DO NOT SCALE DRAWING