

CATALOG CODE

RT-050-XX-XX

TORQUE IN-LBS
01
02
03

SHAFT END TYPE
01- FLAG
02- STRAIGHT
03- KNURLED SHAFT END
04- DUAL FLAG
05- DUAL STRAIGHT
06- DUAL KNURLED SHAFT END

DYNAMIC TORQUE	
NOMINAL TORQUE (IN-LBS)	TOLERANCE
01	±30%
02	±30%
03	±25%

PRODUCT TORQUE SPECIFICATION AT +20°C.

NOTES:

1. USER MUST DETERMINE FITNESS FOR USE IN APPLICATION.
2. ENVIRONMENTAL CONDITIONS: -20° TO +80°C. UP TO 10% OF LIFE CYCLES AT HOT AND COLD CONDITIONS.
3. LIFE: 50,000 CYCLES.
ONE CYCLE CONSISTS OF 90° CW AND 90° CCW AT 10% DUTY CYCLE FOR SPEEDS LESS THAN 100RPM.
- [4] HINGE DESIGNED TO SUPPORT A MINIMAL AXIAL FORCE IN DIRECTION SHOWN, NOT DESIGNED TO SUPPORT AXIAL FORCE IN THE OPPOSITE DIRECTION.
5. MATERIALS:
ZINC DIE CAST HOUSINGS & FLAG SHAFT ENDS
STEEL STRAIGHT SHAFT ENDS
HARDENED STEEL SHAFT
HARDENED STEEL TORQUE CLIPS
MINERAL OIL BASED LUBRICANT
6. FINISH:
NON-COSMETIC PLAIN.
CLEAR CHROMATE RUST PREVENTATIVE COATING ON THE STRAIGHT SHAFT.
7. SHIP ANGLE 0° ±5° BETWEEN HOUSINGS.
8. DESIGNED TO ACCEPT M2 OR #2 SCREW OR EQUIVALENT.

SPECIFICATION SUBJECT TO CHANGE

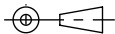
	ECO NO: 09109	PART LIFECYCLE: RELEASED	
	APPROVED BY: BILL WARREN	DEVELOPMENT CYCLE: PRODUCTION	
	APPROVED DATE: 01MAY26	DESCRIPTION:	
	PROJECT NO: 0	<h2>SALES DRAWING</h2>	
ENGINEER: BILL WARREN			
REELL PRECISION MANUFACTURING 1259 WILLOW LAKE BOULEVARD SAINT PAUL, MINNESOTA 55110-5103, USA	DRAWN BY: DERICK OFFOR	PART NO: RT-050	
THIS PRINT IS THE CONFIDENTIAL PROPERTY OF REELL PRECISION MFG.	THIRD ANGLE PROJECTION 	SCALE: 2:1	REV: L
INTERPRET PRINT PER ASME Y14.5M-2009	DIMENSIONS: mm	DO NOT SCALE DRAWING	SHEET 1 OF 8

RT - 050 - XX - 01

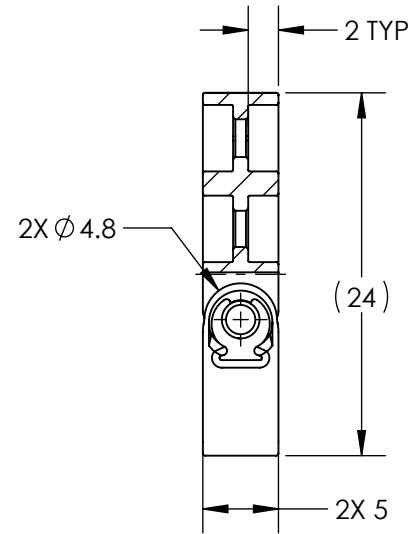
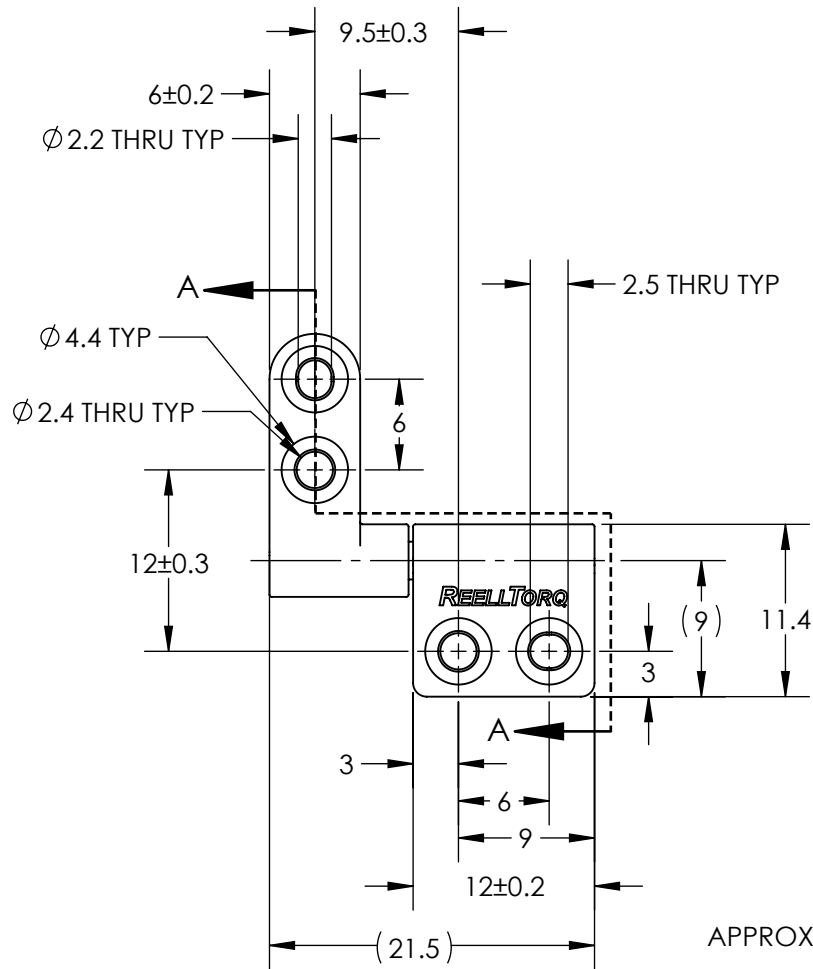

SECTION A-A

APPROXIMATE WEIGHT: 6 GRAMS

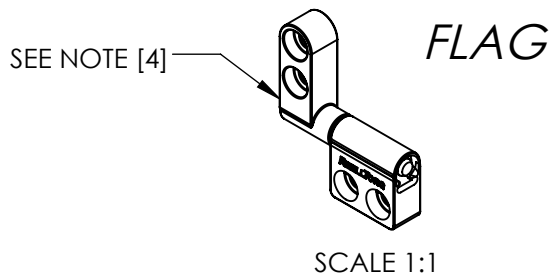

SCALE 1:1

SPECIFICATION SUBJECT TO CHANGE

ALL DIMENSIONS REFERENCE
SEE CAD MODEL FOR UNSPECIFIED FEATURES.

	ECO NO: 09109	PART LIFECYCLE: RELEASED	
	APPROVED BY: BILL WARREN	DEVELOPMENT CYCLE: PRODUCTION	
	APPROVED DATE: 01MAY26	DESCRIPTION:	
	PROJECT NO: 0	SALES DRAWING	
REELL PRECISION MANUFACTURING 1259 WILLOW LAKE BOULEVARD SAINT PAUL, MINNESOTA 55110-5103, USA	ENGINEER: BILL WARREN	PART NO: RT-050	
	DRAWN BY: DERICK OFFOR		
THIS PRINT IS THE CONFIDENTIAL PROPERTY OF REELL PRECISION MFG.	THIRD ANGLE PROJECTION 	SCALE: 2:1	
INTERPRET PRINT PER ASME Y14.5M-2009	DIMENSIONS: mm	DO NOT SCALE DRAWING	SHEET 2 OF 8

RT - 050 - XX - 04

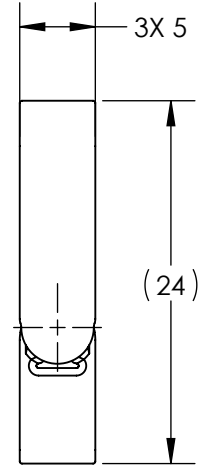
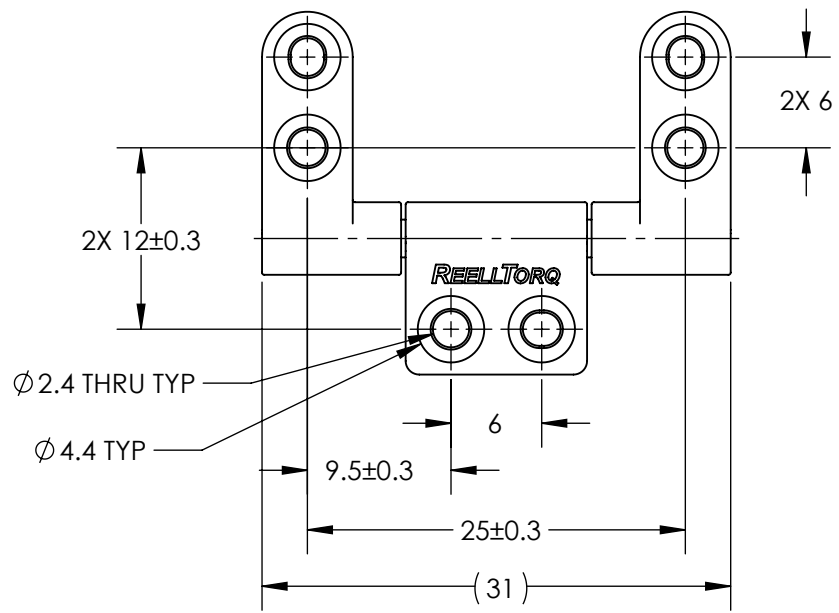

SEE RT-050 SINGLE FLAG ASSEMBLY DRAWING FOR OTHER DIMENSIONS
 APPROXIMATE WEIGHT: 8.5 GRAMS

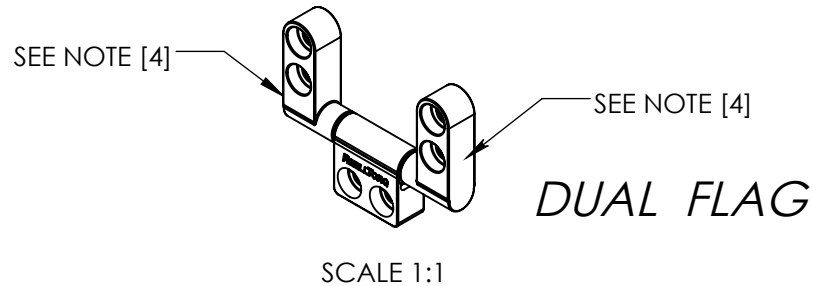

ALL DIMENSIONS REFERENCE
 SEE CAD MODEL FOR UNSPECIFIED FEATURES.

SPECIFICATION SUBJECT TO CHANGE

	ECO NO: 09109	PART LIFECYCLE: RELEASED	
	APPROVED BY: BILL WARREN	DEVELOPMENT CYCLE: PRODUCTION	
	APPROVED DATE: 01MAY26	DESCRIPTION:	
	PROJECT NO: 0	SALES DRAWING	
REELL PRECISION MANUFACTURING 1259 WILLOW LAKE BOULEVARD SAINT PAUL, MINNESOTA 55110-5103, USA	ENGINEER: BILL WARREN	RT-050	
THIS PRINT IS THE CONFIDENTIAL PROPERTY OF REELL PRECISION MFG.	DRAWN BY: DERICK OFFOR		
INTERPRET PRINT PER ASME Y14.5M-2009	THIRD ANGLE PROJECTION 	PART NO: RT-050	SCALE: 2:1
	DIMENSIONS: mm	DO NOT SCALE DRAWING	SHEET 3 OF 8

RT - 050 - XX - 02

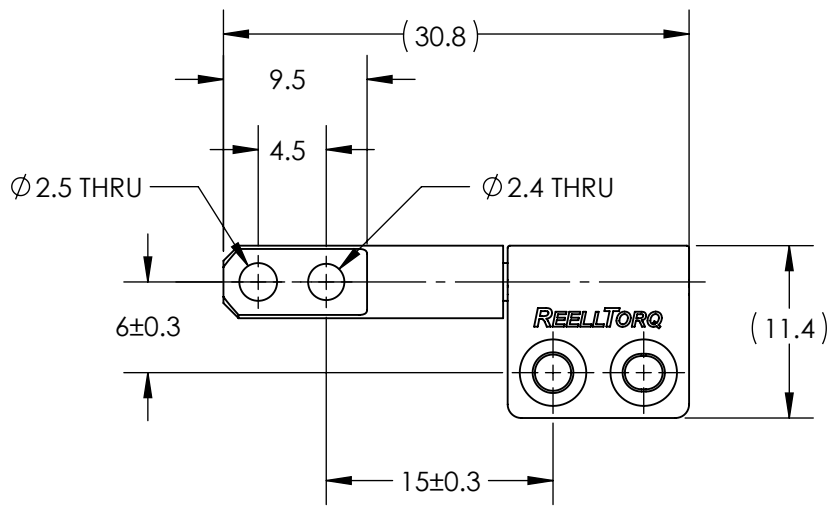
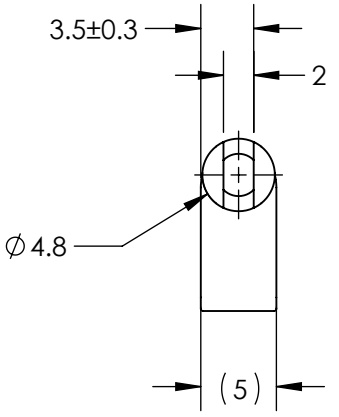

SEE SINGLE FLAG ASSEMBLY DRAWING FOR UNSPECIFIED BRACKET DIMENSIONS
 APPROXIMATE WEIGHT: 5 GRAMS

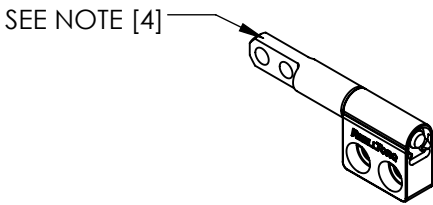

STRAIGHT

SCALE 1:1

ALL DIMENSIONS REFERENCE
 SEE CAD MODEL FOR UNSPECIFIED FEATURES.

SPECIFICATION SUBJECT TO CHANGE

	ECO NO: 09109	PART LIFECYCLE: RELEASED	
	APPROVED BY: BILL WARREN	DEVELOPMENT CYCLE: PRODUCTION	
	APPROVED DATE: 01MAY26	DESCRIPTION:	
	PROJECT NO: 0	SALES DRAWING	
REELL PRECISION MANUFACTURING 1259 WILLOW LAKE BOULEVARD SAINT PAUL, MINNESOTA 55110-5103, USA	ENGINEER: BILL WARREN	RT-050	
	DRAWN BY: DERICK OFFOR		
THIS PRINT IS THE CONFIDENTIAL PROPERTY OF REELL PRECISION MFG.	THIRD ANGLE PROJECTION 	PART NO:	REV: L
INTERPRET PRINT PER ASME Y14.5M-2009	DIMENSIONS: mm	SCALE: 2:1	DO NOT SCALE DRAWING

RT - 050 - XX - 05

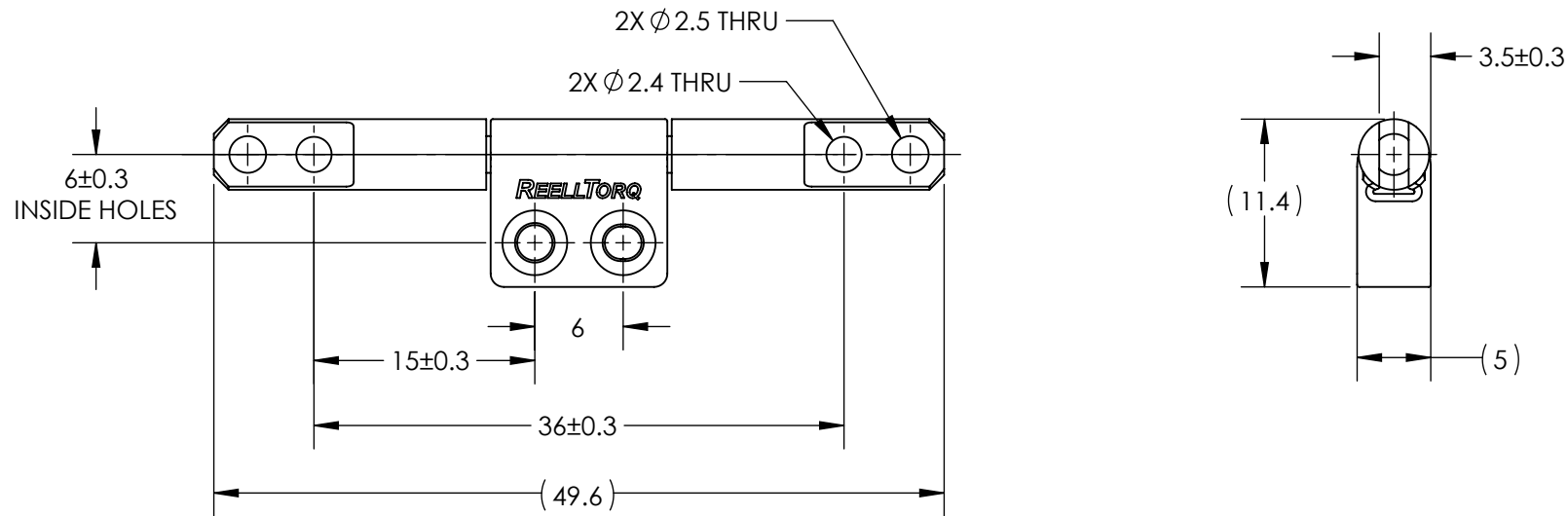

SEE RT-050 SINGLE FLAG ASSEMBLY DRAWING FOR UNSPECIFIED BRACKET DIMENSIONS
 SEE RT-050 STRAIGHT ASSEMBLY DRAWING FOR OTHER DIMENSIONS
 APPROXIMATE WEIGHT: 6.7 GRAMS

SEE NOTE [4] *DUAL STRAIGHT*

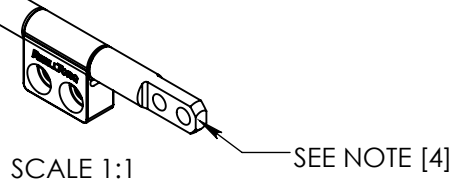

ALL DIMENSIONS REFERENCE
 SEE CAD MODEL FOR UNSPECIFIED FEATURES.

SPECIFICATION SUBJECT TO CHANGE

	ECO NO: 09109	PART LIFECYCLE: RELEASED	
	APPROVED BY: BILL WARREN	DEVELOPMENT CYCLE: PRODUCTION	
	APPROVED DATE: 01MAY26	DESCRIPTION:	
	PROJECT NO: 0	SALES DRAWING	
REELL PRECISION MANUFACTURING 1259 WILLOW LAKE BOULEVARD SAINT PAUL, MINNESOTA 55110-5103, USA	ENGINEER: BILL WARREN	RT-050	
THIS PRINT IS THE CONFIDENTIAL PROPERTY OF REELL PRECISION MFG.	DRAWN BY: DERICK OFFOR		
INTERPRET PRINT PER ASME Y14.5M-2009	THIRD ANGLE PROJECTION 	PART NO: RT-050	SCALE: 2:1
	DIMENSIONS: mm	DO NOT SCALE DRAWING	SHEET 5 OF 8

RT - 050 - XX - 03

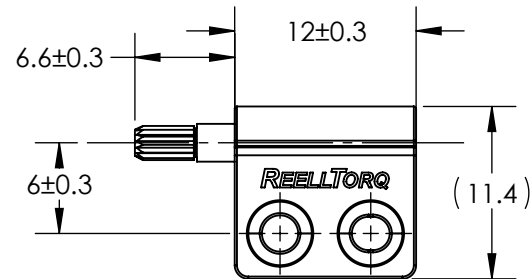
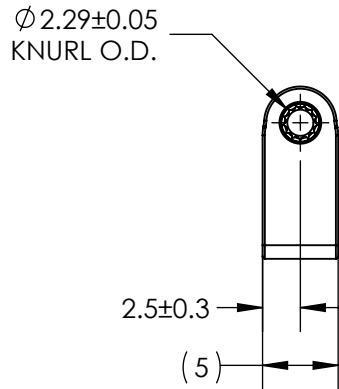

SEE SINGLE FLAG ASSEMBLY DRAWING FOR UNSPECIFIED BRACKET DIMENSIONS

APPROXIMATE WEIGHT: 4 GRAMS

SEE NOTE [4]

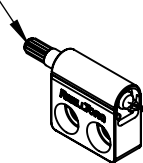

SUPPORT ON
END OF SHAFT
WHEN INSTALLING
PART ONTO KNURL

ALL DIMENSIONS REFERENCE
SEE CAD MODEL FOR UNSPECIFIED FEATURES.

SPECIFICATION SUBJECT TO CHANGE

	ECO NO: 09109	PART LIFECYCLE: RELEASED	
	APPROVED BY: BILL WARREN	DEVELOPMENT CYCLE: PRODUCTION	
	APPROVED DATE: 01MAY26	DESCRIPTION:	
	PROJECT NO: 0	SALES DRAWING	
REELL PRECISION MANUFACTURING 1259 WILLOW LAKE BOULEVARD SAINT PAUL, MINNESOTA 55110-5103, USA	ENGINEER: BILL WARREN	PART NO: RT-050	
THIS PRINT IS THE CONFIDENTIAL PROPERTY OF REELL PRECISION MFG.	DRAWN BY: DERICK OFFOR		
INTERPRET PRINT PER ASME Y14.5M-2009	THIRD ANGLE PROJECTION 	SCALE: 2:1	DO NOT SCALE DRAWING
	DIMENSIONS: mm	SHEET 6 OF 8	

RT - 050 - XX - 06

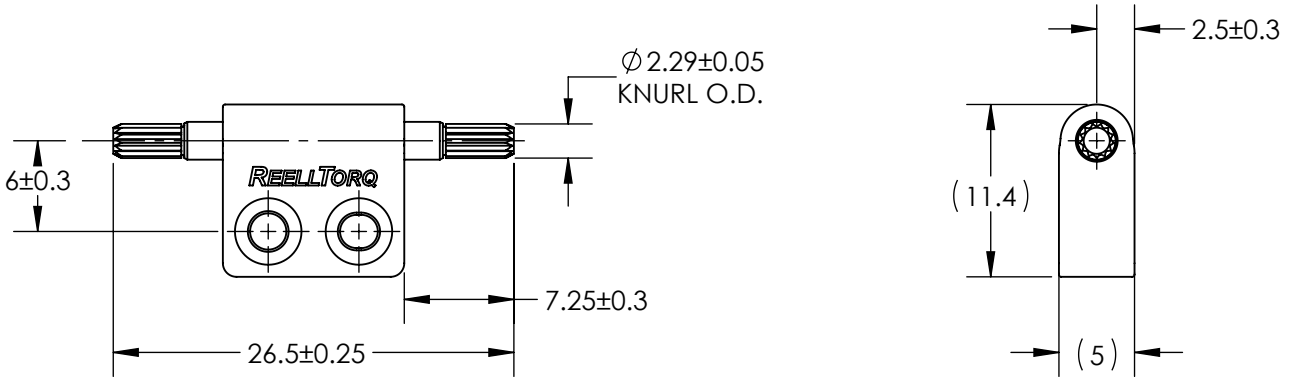

SEE RT-050 SINGLE FLAG ASSEMBLY DRAWING FOR UNSPECIFIED BRACKET DIMENSIONS
 SEE RT-050 KNURLED SHAFT END ASSEMBLY DRAWING FOR OTHER DIMENSIONS
 APPROXIMATE WEIGHT: 3.6 GRAMS

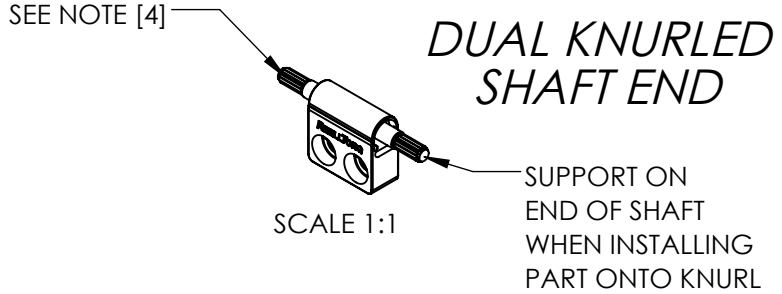

ALL DIMENSIONS REFERENCE
 SEE CAD MODEL FOR UNSPECIFIED FEATURES.

SPECIFICATION SUBJECT TO CHANGE

	ECO NO: 09109	PART LIFECYCLE: RELEASED	
	APPROVED BY: BILL WARREN	DEVELOPMENT CYCLE: PRODUCTION	
	APPROVED DATE: 01MAY26	DESCRIPTION:	
	PROJECT NO: 0	SALES DRAWING	
REELL PRECISION MANUFACTURING 1259 WILLOW LAKE BOULEVARD SAINT PAUL, MINNESOTA 55110-5103, USA	ENGINEER: BILL WARREN	PART NO: RT-050	
THIS PRINT IS THE CONFIDENTIAL PROPERTY OF REELL PRECISION MFG.	DRAWN BY: DERICK OFFOR		
INTERPRET PRINT PER ASME Y14.5M-2009	THIRD ANGLE PROJECTION 	SCALE: 2:1	DO NOT SCALE DRAWING
	DIMENSIONS: mm		SHEET 7 OF 8

RT-050							
MATERIAL	D1	D2	L1	L2	OD	WALL	GAP
DIE CAST ZINC	2.44+/-0.03	2.04+/-0.03	3.5 +/-0.15	7 MIN	4 MIN	1 MIN	0.1 nominal
DIE CAST ALUMINUM							
MILD STEEL	2.55+/-0.03	2.06+/-0.015					
WROUGHT ALUMINUM							

*RECOMMENDED
MATING GEOMETRY
FOR KNURLED
SHAFT END*

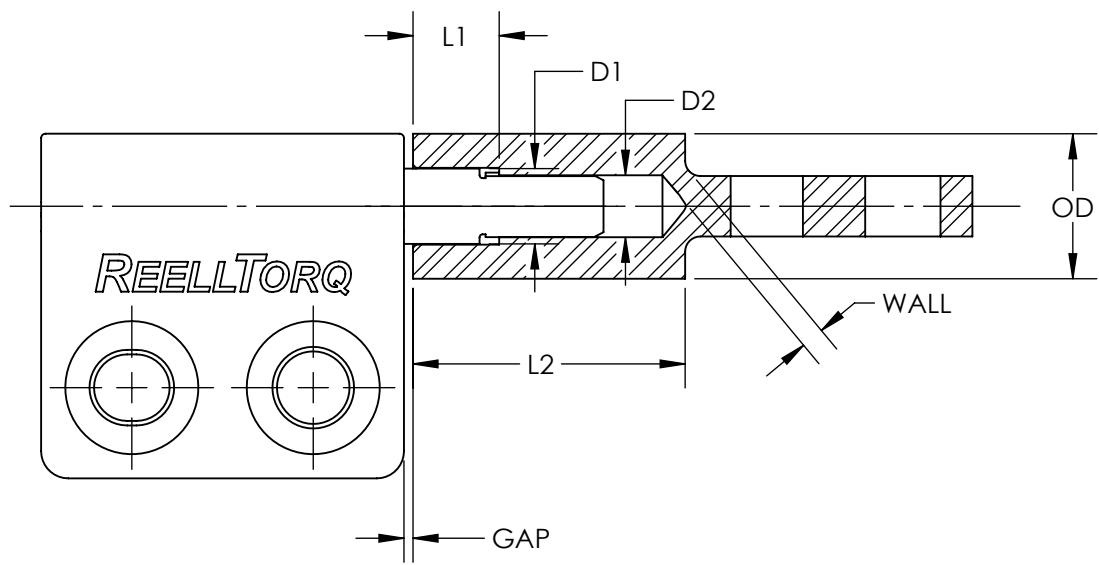

SCALE 4 : 1

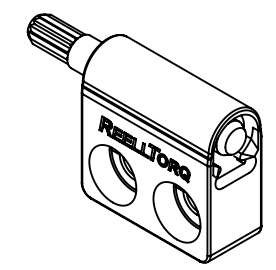
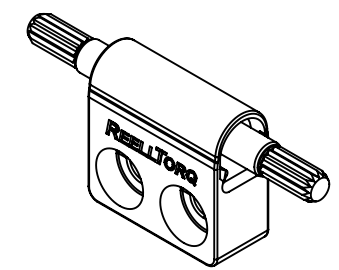

SPECIFICATION SUBJECT TO CHANGE

<p>REELL PRECISION MANUFACTURING 1259 WILLOW LAKE BOULEVARD SAINT PAUL, MINNESOTA 55110-5103, USA</p>	ECO NO: 09109	PART LIFECYCLE: RELEASED
	APPROVED BY: BILL WARREN	DEVELOPMENT CYCLE: PRODUCTION
	APPROVED DATE: 01MAY26	DESCRIPTION:
	PROJECT NO: 0	SALES DRAWING
ENGINEER: BILL WARREN	DRAWN BY: DERICK OFFOR	PART NO: RT-050
THIS PRINT IS THE CONFIDENTIAL PROPERTY OF REELL PRECISION MFG.	THIRD ANGLE PROJECTION 	REV: L
INTERPRET PRINT PER ASME Y14.5M-2009	DIMENSIONS: mm	SCALE: 2:1 DO NOT SCALE DRAWING SHEET 8 OF 8