

2.) **REELL Label Version B:** Version B is used to identify a pallet load of the same part numbers. Each pallet load must contain two REELL Labels on adjacent sides and each carton must contain two REELL Production Labels on adjacent sides.

**Note:** The Reell address listed is just an example – address may be to a different location.

### MASTER LOAD LABEL

<b>From:</b> Supplier Name Street Address City, State, Zip	<b>To:</b> Reell Precision Manufacturing 1259 Willow Lake Boulevard Saint Paul, MN 55110-5103 USA
<b>Part# - 123456-000</b> <b>Revision - C</b> <b>Quantity - 100000</b> <b>MASTER LOAD</b>	
<b>REELL P.O. # - 789123</b> <b>Supplier - Testco</b> <b>Country of Origin - USA</b>	<b>Ship Date - 2/26/2019</b> <b>Box ____ of ____</b>

**20 Point Font Size**

**24 Point Font Size**

**14 Point Font Size**

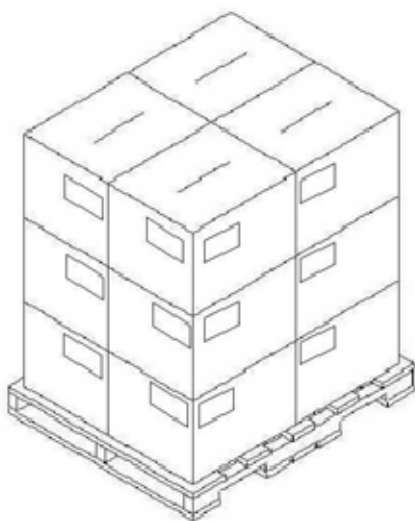

**Labels (two per carton)**

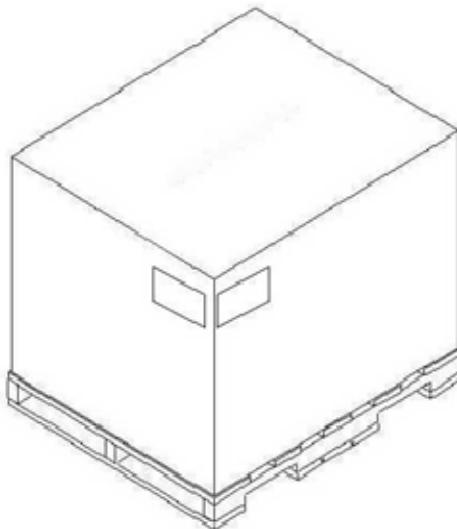

**(2) Labels on stretch wrap**

**3.) REELL Label Version C:** Version C is used to identify a pallet load of different part numbers. Each pallet load must contain two REELL Labels on adjacent sides and each carton must contain two REELL Production Labels on adjacent sides.

**Note:** The Reell address listed is just an example – address may be to a different location.

**MIXED LOAD LABEL**

**36 Point  
Font Size**

**14 Point Font Size**

<b>From:</b> Supplier Name Street Address City, State, Zip	<b>To:</b> Reell Precision Manufacturing 1259 Willow Lake Boulevard Saint Paul, MN 55110-5103 USA	
<b>MIXED LOAD</b>		
		
REELL P.O. # -	789123	Ship Date - 2/26/2019
Supplier -	Testco	
Country of Origin -	USA	Box ____ of ____

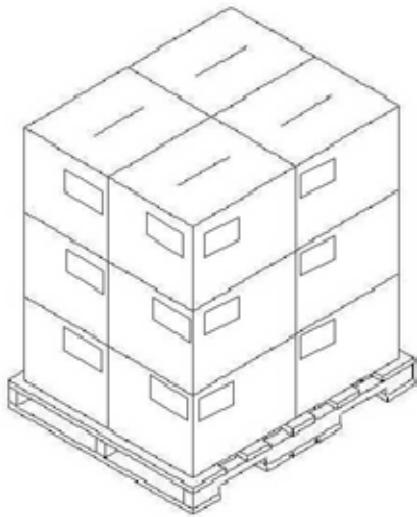

**Labels (two per carton)**

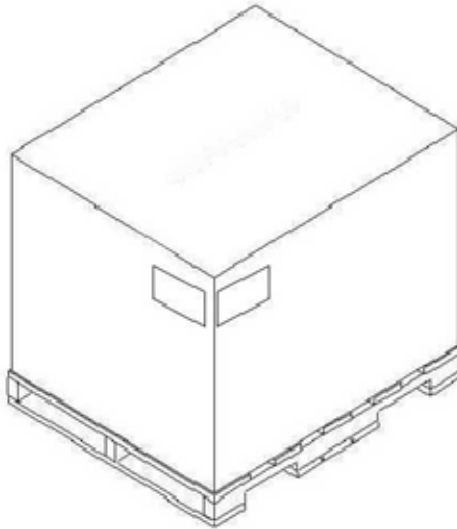

**(2) Labels on stretch wrap**



## Appendix

### Table 1 Part Submission Warrant Requirements

Requirements	Level 1	Level 2	Level 3	Level 4
1 Design Records (Prints/Specs)			*	*
2 Process Flow Diagrams			S	*
3 Process FMEA			S	*
4 Dimensional Results, FAI		S	S	*
5 Capability Study's			S	*
6 Measurement System Analysis Studies (GR&R)			S	*
7 Control Plan			S	*
8 Material Certification			S	*
9 Part Submission Warrant (PSW)	S	S	S	*
10 Sample Product		S	S	*
11 Inspection Gauge Calibration Records			*	*

S = The supplier shall submit this document to the person(s) listed on the Warrant Form and retain a copy of records for future reference.

R = The supplier shall retain at appropriate locations, including manufacturing, and make readily available to the customer representative upon request.

\* The supplier shall submit to Reell upon special request.